

Choosing PAG shows others
that you demand the best

Paglight C6 Kit

The only broadcast-quality 6V camcorder lighting kit



Miniature 6V Light

PAG was the first to introduce an ultra-compact, professional 6V camera light, designed specifically for hand-held camcorders, when it launched the Paglight C6 lighting kit in 2002.

The Paglight C6 is supplied in a kit that includes a 6V 8Ah Ni-MH battery and a multi-function charger. The battery will run the Paglight C6 with a 20W lamp for two and three quarter hours.

Broadcast Quality

The design of the Paglight C6 is based on the larger ENG Paglight, the camera top-light that can be seen in action on TV news bulletins almost every night. It is designed to complement available light as a 'fill' or 'front light' and incorporates professional features, such as the patented plug-in lamp holder system that makes lamp-changing quick and easy, a focusable beam angle, and professional filters.

Cool-running

The Paglight C6 is constructed from a glass reinforced engineering polymer that provides strength and temperature stability. The combination of this modern material and the patented heat dissipation system ensures the Paglight C6 is cool-running at all times, and therefore comfortable to handle.

Plug-in Lamp Holders

PAG's patented plug-in lamp holder system makes fitting a lamp quick and easy. The Paglight C6 is supplied with a lamp holder and a 20W 6V, G4-size tungsten halogen lamp. 10W and 30W lamps are also available. Additional lamp holders enable exchange between lamps of varying wattages, quickly and easily, without directly handling the lamp.



Fully Focusable

The lamp head is fully-focusable, with a smooth transition from spot to flood. The ability to change the beam angle allows you to reduce the light output without the need for a dimmer, which affects colour temperature.

When not in use, lamp holders should be stored in their high-strength, heat-resistant polymer lamp protector.

Professional Features

An accessory ring fits to the front of the light and accommodates the professional, snap-in accessories: a diffuser, a dichroic filter and a pair of barn doors.

When filming in subdued light conditions, or poor daylight, it is all too easy to over-light your subject. In order to avoid this you can use the diffuser to soften the light. It can also be used to soften the harsh shadows caused by a bright light source, such as direct sunlight. The spot-and-flood facility helps give you further fine control over light intensity.

When supplementing daylight with your Paglight C6, the colour temperature of the light output must be corrected to match daylight. The dichroic filter raises the colour temperature of the light output from 3200°K (halogen) to 5600°K (daylight). Colour temperature is a measurement of the colour of light, not the brightness, and is not affected by lamp wattage.

The accessories also include a pair of barn doors, to flag off unwanted light. They double as protectors for the filters when the light is not in use.

PAG's Softlight Diffuser & Filter Kit (Model 9983) can also be used with Paglight C6. It is intended for ultra-soft lighting effects and colour temperature correction.

Perfect Positioning

The support base of the lamphead is a multi-directional mounting which allows the light to be adjusted vertically and horizontally, and maintained in the desired position.

The Paglight C6 base incorporates a 1/4" Whit. bush and is supplied with a square shoe plate, allowing the unit to be mounted to camcorders with an accessory shoe. For camcorders without an accessory shoe PAG provides an Accessory Mounting Bracket

(Model 1021) that can be fitted to the 1/4" Whit. bush on the base of the camcorder. It allows both the C6 and a microphone to be mounted to the camcorder. A short Accessory/Extender Arm (Model 1020) with two accessory shoes is available that also allows two accessories to be mounted to the camcorder. The Paglight C6 base has a flying lead terminated with a professional-quality connector, incorporating gold-plated contacts, for connection to the C6 PowerPack.

All Inclusive Lighting Kit

Paglight C6 is powered from its own 6V 8Ah Ni-MH PowerPack. This rechargeable battery, weighing less than 1kg, is supplied with a detachable shoulder strap. A belt clip that enables the battery to be worn on your trouser belt, is available separately. When fully charged the battery will provide two and three quarter hours of continuous run-time with a 20W lamp. An additional battery will enable you to shoot for a whole day.

The PAG Power Charger will charge the battery in three to four hours, from fully discharged. It will automatically recover the battery prior to fast-charging, if it has been deeply discharged. The charger also provides a maintenance top-up charge after full charge. These automatic functions are indicated by a single LED. The charger has an interchangeable power plug .

Paglight C6 Lighting Kit, Model No. 1001

The kit includes the following:

- ▶ Paglight C6
- ▶ Plug-in Lampholder and 20W lamp
- ▶ Accessory ring, daylight filter, diffuser & barndoors
- ▶ Camera Shoe Plate
- ▶ PAG C6 PowerPack with shoulder strap
- ▶ PAG Power Charger with plug

Components

Additional C6 batteries, lamps and individual Paglight C6 components can be purchased on-line at www.paguk.com/C6. Alternatively, contact PAG Ltd. for full details, including prices, by emailing sales@paguk.com

Paglight C6 Components:

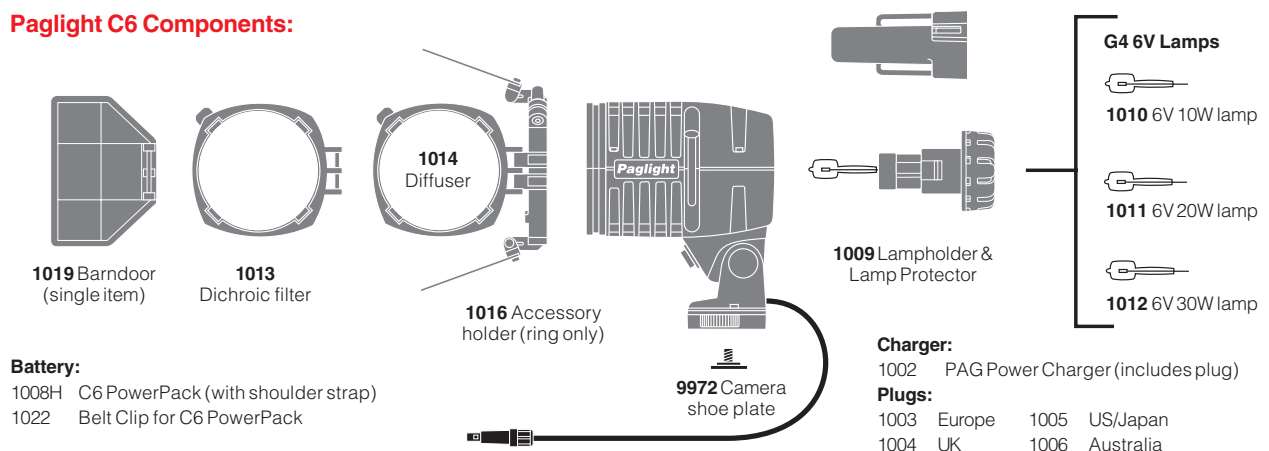

Registered Design No. 2071515 Patent No. 2335027

PAG Ltd.
565 Kingston Road
Raynes Park
London SW20 8SA

T +44 (0) 20 8543 3131
F +44 (0) 20 8540 4116
E sales@paguk.com
www.paguk.com

© 2009 PAG Ltd. PAG is the trademark of PAG Ltd.